

A

B

D

E

OVERALL ELEVATION PLAN

1. Scale - N.T.S.

DRAWING NO:

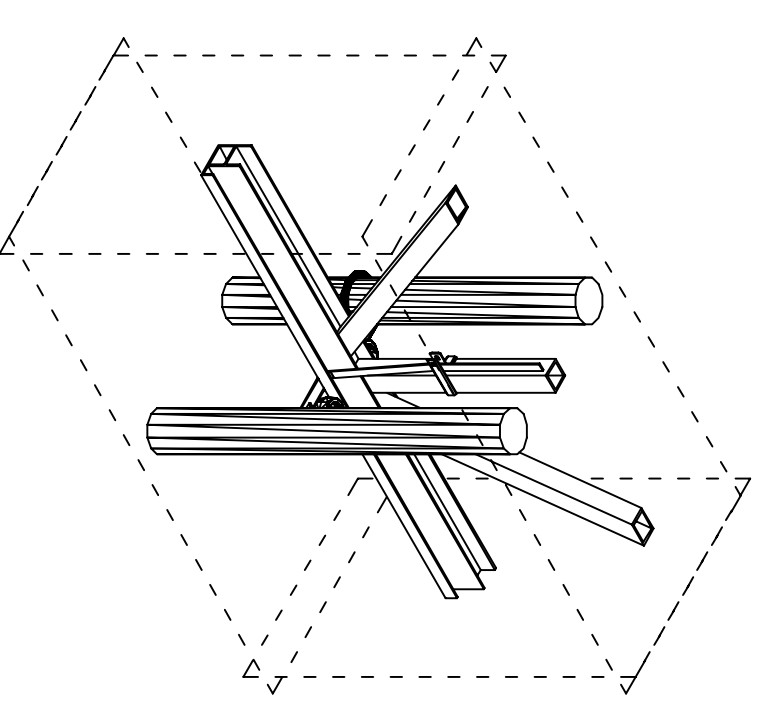
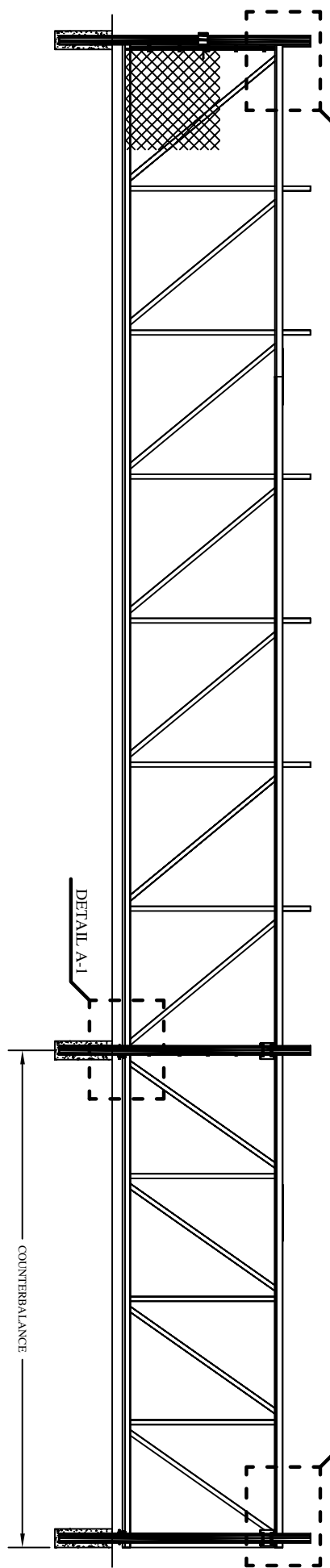

DETAIL A-1: BOTTOM ROLLER ASSEMBLY

1. Diagram shown in South-West Isometric View.
 2. Scale - 3/4" = 1'-0"

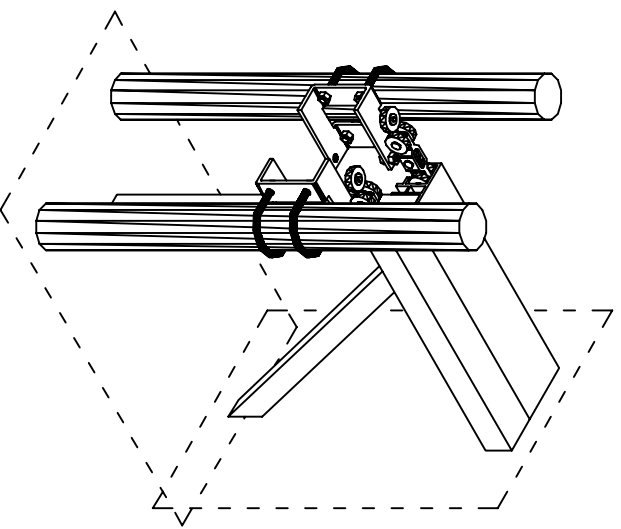

DETAIL A-2: TRUCK ASSEMBLY

1. Diagram shown in North-East Isometric View.
 2. Top-Track shown off truck assembly for demonstration.
 3. Scale - 3/4" = 1'-0"

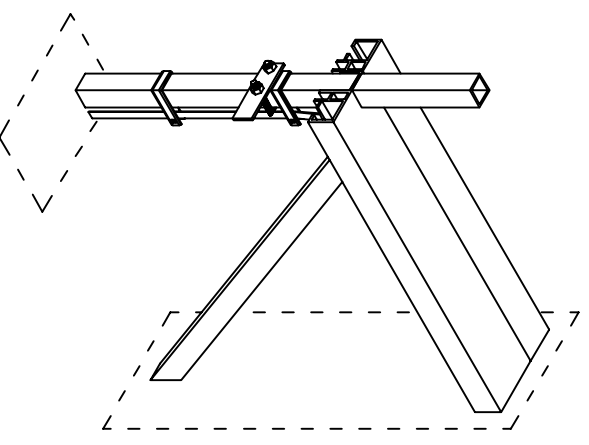

DETAIL A-3: TOP-TRACK ASSEMBLY

1. Diagram shown in South-West Isometric View.
 2. Scale - 3/4" = 1'-0"



Dual-Track Aluminum Slide Gate
 Elevation Details

DATE: 10-07-2008 APPROVED BY: JMP

SCALE: VAR DRAWN BY: MJL REV: 1

A

B

C

D

E

4

3

2

1